

CASE

**DV SERIES
TANDEM DRUM VIBRATORY ROLLERS**

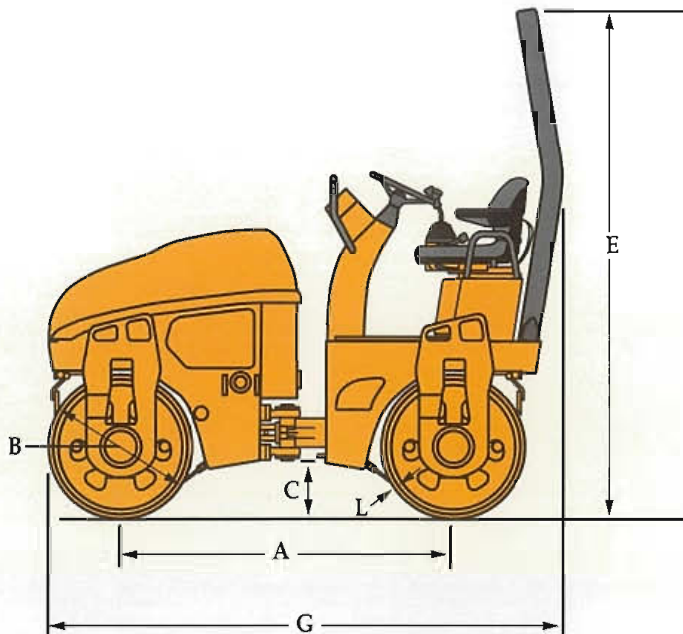

GENERAL DIMENSIONS



DV201

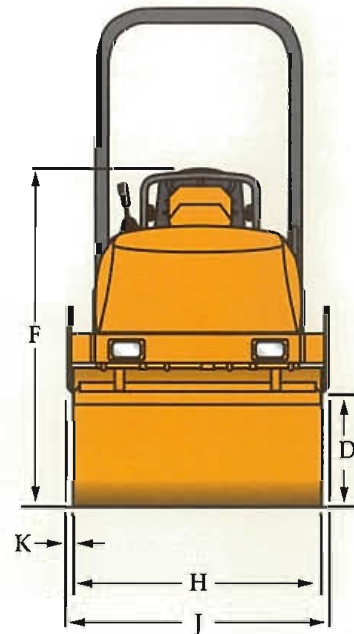

DV202

DV204

DIMENSIONS

A	Wheel base	67.6 in (1716 mm)	67.6 in (1716 mm)	67.6 in (1716 mm)
B	Drum diameter	29 in (740 mm)	29 in (740 mm)	29.4 in (746 mm)
C	Ground clearance	12 in (310 mm)	12 in (310 mm)	12 in (310 mm)
D	Curb clearance	23 in (590 mm)	23 in (590 mm)	23 in (590 mm)
E	Overall height	105 in (2680 mm)	105 in (2680 mm)	105 in (2680 mm)
F	Folded ROPS height	72 in (1825 mm)	72 in (1825 mm)	72 in (1825 mm)
G	Overall length	104 in (2640 mm)	104 in (2640 mm)	104 in (2640 mm)
H	Drum width	39.4 in (1000 mm)	47.2 in (1200 mm)	51.2 in (1300 mm)
J	Overall width	42.9 in (1090 mm)	50.8 in (1290 mm)	54.9 in (1396 mm)
K	Frame extensions	1.8 in (45 mm)	1.8 in (45 mm)	1.8 in (45 mm)
L	Drum thickness	0.5 in (12 mm)	0.5 in (12 mm)	0.6 in (16 mm)

WEIGHT

Operating weight	5,510 lbs (2500 kg)	5,950 lbs (2700 kg)	7,720 lbs (3500 kg)
Front drum weight	2,755 lbs (1250 kg)	2,975 lbs (1350 kg)	3,860 lbs (1750 kg)
Rear drum weight	2,755 lbs (1250 kg)	2,975 lbs (1350 kg)	3,860 lbs (1750 kg)
Front drum linear load	70 lb/in (12.5 kg/cm)	63 lb/in (11.3 kg/cm)	75 lb/in (13.5 kg/cm)
Rear drum linear load	70 lb/in (12.5 kg/cm)	63 lb/in (11.3 kg/cm)	75 lb/in (13.5 kg/cm)

ENGINE

Make	Deutz	Deutz	Deutz
Type	F2L1011F	F2L1011F	F3L1011F
Rated horsepower	27 hp (20 kW)	27 hp (20 kW)	38 hp (27.6 kW)
Fuel consumption	0.8 gal/hr (3 L/hr)	0.8 gal/hr (3 L/hr)	0.9 gal/hr (3.5 L/hr)

TRAVEL

Drive.....	Hydrostatic.....	Hydrostatic.....	Hydrostatic.....
Variable displacement axial piston type drive pump.....	1.....	1.....	1.....
Hydraulic fixed displacement drum drive motors.....	2.....	2.....	2.....
Service brake.....	Hydrostatic.....	Hydrostatic.....	Hydrostatic.....
Parking/Emergency brake.....	Multi-disc.....	Multi-disc.....	Multi-disc.....
Maximum relief pressure.....	5075 PSI (35 MPA).....	5075 PSI (35 MPA).....	5075 PSI (35 MPA).....
Working speeds.....	4.7 mph (7.5 km/h).....	4.7 mph (7.5 km/h).....	4.7 mph (7.5 km/h).....
Maximum travel speed.....	8.5 mph (13.6 km/h).....	8.5 mph (13.6 km/h).....	6.2 mph (10 km/h).....
Gradeability (vibration off).....	40%.....	40%.....	40%.....

VIBRATION

Hydraulic circuit type.....	closed.....	closed.....	closed.....
Pump type.....	Gear.....	Gear.....	Gear.....
Fixed displacement hydraulic motor.....	2.....	2.....	2.....
Maximum relief pressure.....	3480 PSI (24 MPA).....	3480 PSI (24 MPA).....	3480 PSI (24 MPA).....
Vibration.....	Eccentric.....	Eccentric.....	Eccentric.....
Frequency — low.....	3180 VPM (53 Hz).....	3180 VPM (53 Hz).....	3180 VPM (53 Hz).....
— high.....	3720 VPM (62 Hz).....	3720 VPM (62 Hz).....	3720 VPM (62 Hz).....
Rated amplitude.....	0.0185 in (0.47 mm).....	0.0185 in (0.47 mm).....	0.0177 in (0.45 mm).....
Centrifugal force — low.....	4580 lbs (20.8 kN).....	5242 lbs (23.8 kN).....	6476 lbs (29.4 kN).....
— high.....	6277 lbs (28.5 kN).....	7159 lbs (32.5 kN).....	8877 lbs (40.3 kN).....
Dynamic linear load — low.....	116 lbs/in (0.02 kN/mm).....	111 lbs/in (0.02 kN/mm).....	127 lbs/in (0.02 kN/mm).....
— high.....	159 lbs/in (0.03 kN/mm).....	152 lbs/in (0.03 kN/mm).....	173 lbs/in (0.03 kN/mm).....
Watering system.....	Pressurized.....	Pressurized.....	Pressurized.....
Front tank capacity.....	14 gal (53 L).....	14 gal (53 L).....	17.7 gal (67 L).....
Rear tank capacity.....	39.6 gal (150 L).....	39.6 gal (150 L).....	42.3 gal (160 L).....
Tank type.....	Polyurethane.....	Polyurethane.....	Polyurethane.....

DV201 DV202 DV204

STEERING

Pump type.....	Gear.....	Gear.....	Gear.....
Cylinders.....	1.....	1.....	1.....
Angle (left & right).....	33°.....	33°.....	33°.....
Oscillation angle.....	10°.....	10°.....	10°.....
Inner turning radius.....	97.6 in.....	93.7 in.....	99.6 in.....
	(2480 mm).....	(2380 mm).....	(2530 mm).....
Relief pressure.....	2537 PSI.....	2537 PSI.....	2537 PSI.....
	(17.5 MPA).....	(17.5 MPA).....	(17.5 MPA).....

ELECTRICAL SYSTEM

Voltage.....	12 volt.....	12 volt.....	12 volt.....
Batteries.....	1.....	1.....	1.....
Amp hour.....	72.....	72.....	72.....
Cold cranking amps.....	640.....	640.....	640.....

MAX. COMPACTED LIFT THICKNESS

Sand/gravel.....	11.8 in.....	11.8 in.....	11.8 in.....
	(300 mm).....	(300 mm).....	(300 mm).....
Mixed soils.....	7.9 in.....	7.9 in.....	7.9 in.....
	(200 mm).....	(200 mm).....	(200 mm).....
Asphalt.....	4.7 in.....	4.7 in.....	4.7 in.....
	(120 mm).....	(120 mm).....	(120 mm).....

DV201 DV202 DV204

CAPACITIES

Fuel tank.....	15.9 gal.....	15.9 gal.....	18.5 gal.....
	(60 L).....	(60 L).....	(70 L).....
Engine oil.....	1.7 gal.....	1.7 gal.....	1.7 gal.....
	(6.5 L).....	(6.5 L).....	(6.5 L).....
Hydraulic reservoir.....	10 gal (38 L).....	10 gal (38 L).....	10 gal (38 L).....
Vibration system (each).....	0.48 gal.....	0.48 gal.....	0.48 gal.....
	(1.8 L).....	(1.8 L).....	(1.8 L).....

OPERATOR'S COMPARTMENT

Insulated from chassis by flexible shock absorbers, handrail, instrument panel anti-vandal guard, exceptional front/rear visibility, ROPS protection, single lever speed and direction control with vibration on/off control.

TANDEM DRUM VIBRATORY ROLLERS

DV201 / DV202 / DV204



STANDARD EQUIPMENT

- Fixed ROPS
- Anti-vandal guard
- Hydrostatic drive for both drums
- Dual vibration
- Front/dual drum vibration control
- Auto vibration stop in neutral
- Articulated chassis
- Hydraulic oil cooler
- Backup alarm
- 2 in (51 mm) retractable seat belt
- Suspension seat with foldable arms
- Pressurized water system
- Machined tapered edge drums
- Vulcollon scrapers, adjustable
- 2-stage water filtration
- Master disconnect switch
- Horn
- Hourmeter
- Emergency stop button
- 4-point lift and tie down provision
- Watering system drains
- Electric fuse protection
- Steering wheel spinner knob
- Spin-on fuel, engine oil and hydraulic filters
- Tool box
- Flip open hood
- Indicator lights
 - Battery
 - Engine oil pressure
 - Intake preheater
 - Engine temperature
 - Parking brake
 - Vibration ON/OFF
 - Sprinkler system ON/OFF

OPTIONAL EQUIPMENT

- Rotating beacon
- Halogen work lights
- Foldable ROPS
- 3" (76 mm) retractable seat belt
- Sunshade for fixed ROPS
- Brake release

NOTE: All specifications are stated in accordance with SAE Standards or Recommended Practices, where applicable.

IMPORTANT: CNH America LLC reserves the right to change these specifications without notice and without incurring any obligation relating to such change. This literature has been published for worldwide circulation. Availability of some models and equipment builds vary according to the country in which the equipment is used. The illustrations and text may include optional equipment and accessories and may not include all standard equipment. Your Case dealer/distributor will be able to give you details of the products and their specifications available in your area.

Safety Never Hurts!™ Always read the Operator's Manual before operating any equipment. Inspect equipment before using it, and be sure it is operating properly. Follow the product safety signs, and use any safety features provided.

NOTE: All engines meet current EPA emission requirements.

CNH AMERICA LLC
700 STATE STREET
RACINE, WI 53404
U.S.A.

CNH CANADA, LTD.
199 BAY STREET
TORONTO, ON M5L 1A9
CANADA

www.casece.com

CASE

CNH CASE IS A BRAND OF CNH. A GLOBAL LEADER FOR CONSTRUCTION EQUIPMENT, AGRICULTURAL EQUIPMENT AND FINANCIAL SERVICES.

Form No. CCE2100403
Case is a registered trademark of CNH America LLC

© 2004 CNH America LLC All rights reserved
Printed in U.S.A.